

GDM-265D

Slag Remove Machine



Working Width:650mm



Product Layout

Easy Removal:

Edge Slag

Edge burr

Surface Spatter

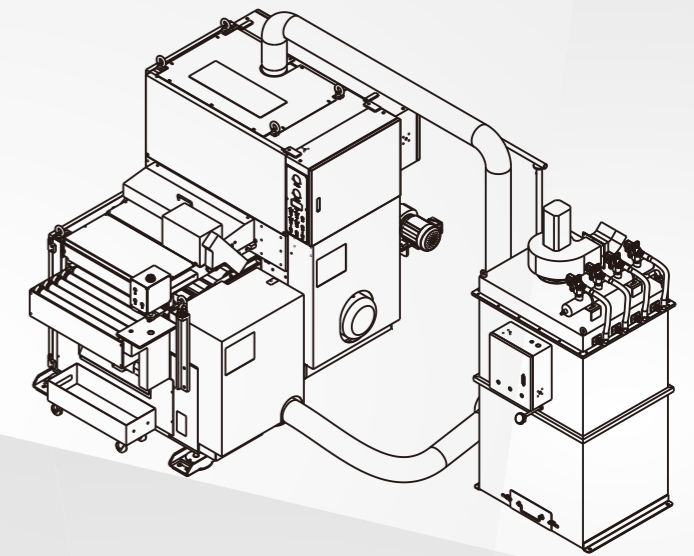

Application



Specification

Power Supply	AC220V/380V/415V
Frequency	50HZ/60HZ
Total Power	~11KW
Running Power	~10KW
Air Power	0.5Mpa
Air Volume of Fan	2*25m³/min
Plate Width	Max.650mm
Plate Thickness	6~60(100mm)
Plate Length	>170mm
Feed Speed	2.0~4.0m/min
Processing	Both Surface
Work-table Size	W675*L1900mm
Work-table Height	900~910mm
Space Area	L2800*W3000mm
Machine Height	2000~2100mm
Net Weight	2200kg+130kg

Features

Machining the **lower & upper** surface same time

Gantry type, continuous feeding

Measure the plate thickness automatically

Efficient work, save labor

Processing the cut edge only

